

# SD 5-100 DB and SI 5-100 IB

## Self-aligning Roller Beds with Rail Bogie

- Robust design with durable rollers.
- Gritblasted steelwork with polyurethane finished coating to endure the abrasive environment of offshore and marine industries.
- Over sized bearings.
- Special formulated high-load polyurethane tire design for high wear resistance.
- Cast steel gearbox with double worm gear arrangement for smooth operation and minimum backlash.
- Solid state inverter for precise speed control.
- Motorised and Idler Rail Bogie versions.



### Applications

- **Wind Tower Fabrication**
- **Offshore and Shipyards**
- **Pressure Vessels**
- **Pipe Lines**



## Technical data

Model		SD-5-DB SI-5-IB	SD-10-DB SI-10-IB	SD-20-B SI-20-IB	SD-40-DB SI-40-IB	SD-60-DB SI-60-IB	SD-80-DB SI-80-IB	SD-100-DB SI-100-IB
Max loading capacity tons /section	Drive unit	2.5	5	10	20	30	40	50
	Idler unit	2.5	5	10	20	30	40	50
Turning Capacity, tons	Drive unit	5	10	20	40	60	80	100
Turning Speed	mm/min	100-1000	100-1000	100-1000	100-1000	100-1000	100-1000	100-1000
Travel speed rail bogie	mm/min	3000	3000	3000	3350	3350	3350	3350
Inner Rail Gauge (G-G)	mm	1435	1435	1435	1700	2000	2000	2200
Vessel Diameter	Min	250	320	500	600	750	850	1000
	Max	2300	2800	3500	4200	4800	5000	5500
Power Supply	50Hz/3ph	380/400/415V	380/400/415V	380/400/415V	380/400/415V	380/400/415V	380/400/415V	380/400/415V
	60Hz/3 ph	440/460/480V	440/460/480V	440/460/480V	440/460/480V	440/460/480V	440/460/480V	440/460/480V
Fuses	Amp	16	16	16	16	32	32	32
Control Voltage	V AC	24	24	24	24	24	24	24
Weight roller bed with rail bogie kg	Drive unit	830	1170	1500	2200	2870	3670	5300
	Idler unit	420	580	750	1100	1430	1830	2700
Dimensions LxHxW	Drive unit	1900/1160/800	2210/1180/945	2400/1210/1035	2880/1300/1165	3090/1425/1310	3270/1425/1380	3630/1700/1550
	Idler unit	1160/1000/800	1400/1020/945	1650/1050/1035	2000/1140/1165	2220/1280/1310	2450/1300/1380	2950/1030/1550
Cable control box	m	10	10	10	10	10	10	10

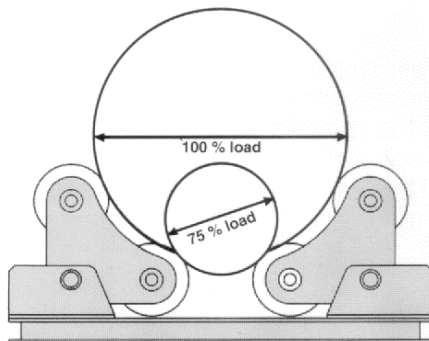

## Ordering Information

### Drive unit

Roller bed SD-5-DB	0370 250 064
Roller bed SD-10-DB	0370 250 066
Roller bed SD-20-DB	0370 250 068
Roller bed SD-40-DB	0370 250 070
Roller bed SD-60-DB	0370 250 072
Roller bed SD-80-DB	0370 250 074
Roller bed SD-100-DB	0370 250 076

### Idler unit

Roller bed SI-5-IB	0370 250 065
Roller bed SI-10-IB	0370 250 067
Roller bed SI-20-IB	0370 250 069
Roller bed SI-40-IB	0370 250 071
Roller bed SI-60-IB	0370 250 073
Roller bed SI-80-IB	0370 250 075
Roller bed SI-100-IB	0370 250 077

## Options

Foot switch	0370 250 301
-------------	--------------



[www.esab.com](http://www.esab.com)

